

M1346-aQ60L-H
M1346-aQ68L-H
M1346-aQ80L-H



Acousto-Optic Modulator

0420

Robust AO Modulator designed for High Power NIR Fibre and DPSS laser applications.

SPECIFICATIONS

Spectral Range:	NIR
A/ R wavelength:	700-900nm, 1064nm
Interaction Medium:	Quartz
Acoustic Velocity:	5.7mm/ μ s
Centre Frequency (fc):	60, 68 or 80MHz
RF Bandwidth (Δ f):	> 15MHz
Input Impedance:	50 Ω
Input VSWR:	< 1.5:1 at fc
Clear Aperture:	9mm (H) x 14 mm (L)
Active Aperture Height (-H)	(Please specify -H)
M1346-aQxxL-3:	3mm
M1346-aQxxL-4:	4mm
M1346-aQxxL-5:	5mm
Optical Insertion Loss:	< 2%
Reflectivity:	< 0.3%/Surface
Laser Polarization:	Vertically Polarized
Water Cooling (minimum):	2litre/minute at < 27°C

TYPICAL PERFORMANCE

Wavelength:	<u>800nm</u>	<u>1064nm</u>
Optical Power (CW):	400 W	400 W
RF Power (nominal):		
H=3	25 W	40 W
H=4	30 W	50 W
H=5	40 W	65 W
Bragg Angle (80MHz):	5.6 mrad	7.5 mrad
Separation Angle (80MHz):	11.2 mrad	14.9 mrad
Input beam diameter	<u>1.6mm</u>	<u>3mm</u>
Optical rise time:	0.18us	0.34us
Diffraction Efficiency:	> 85% *	> 85% *

* 90% typical, single mode input

ALL SPECIFICATIONS SUBJECT TO CHANGE WITHOUT NOTICE
 ISOMET CORP, 10342 Battlevue Parkway, Manassas, VA 20109, USA.
 Tel: (703) 321 8301 Fax: (703) 321 8546
 E-mail: ISOMET@ISOMET.COM Web Page: WWW.ISOMET.COM

Quality Assured.
In-house: Crystal Growth,
Optical Polishing,
A/R coating, Vacuum Bonding

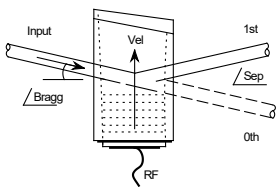

M1346-aQ60L-H
M1346-aQ68L-H
M1346-aQ80L-H



Acousto-Optic Modulator

0420

OUTLINE DRAWING

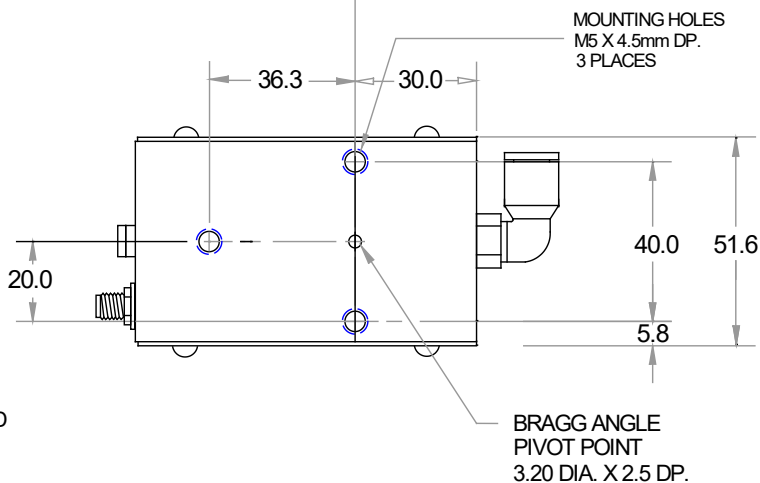
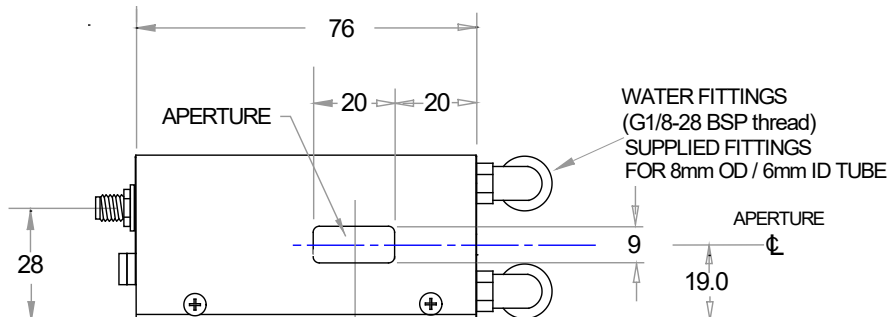
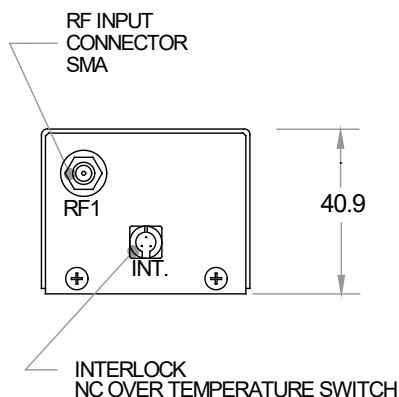

NOTES:

1. THIS DEVICE REQUIRES WATER COOLING TO PREVENT THERMAL RUNAWAY. THE INTEGRAL NC THERMAL INTERLOCK SWITCH OPENS AT 50 DEGREES CENTIGRADE.
2. THE WATER COOLED CASE PARTS ARE ALUMINIUM, IT IS RECOMMENDED THAT A CORROSION INHIBITOR BE ADDED TO THE COOLING SYSTEM.

Refer application note AN1906 regarding Coolant Specification

Standard case parts in contact with coolant fabricated in anodized aluminium

Options: Brass water contacted case parts: -BR
 Copper water contacted case parts: -C

Recommended Driver

Modulator Driver/Amplifier

RA5-60-1-, RA5-68-1-, or RA5-80-1- series

ALL SPECIFICATIONS SUBJECT TO CHANGE WITHOUT NOTICE
 ISOMET CORP, 10342 Battlevue Parkway, Manassas, VA 20109, USA.
 Tel: (703) 321 8301 Fax: (703) 321 8546
 E-mail: ISOMET@ISOMET.COM Web Page: WWW.ISOMET.COM

Quality Assured.
In-house: Crystal Growth, Optical Polishing, A/R coating, Vacuum Bonding